



Accessories Venturi mixer

VM-15,20,25,40,50,65,80

Only by changing the air pressure (air capacity), it is possible to adjust the thermal power while maintaining a constant mixing ratio.

Feature

- 1 The venturi mixer is a device which mixing air and various kind of gas.
- 2 Venturi mixer sucks and mixes gas with negative pressure generated around the nozzle when low pressure air (1 to 10 kPa) passes through the nozzle of the mixer.
- 3 Gas of 1 to 3 kPa is always adjusted to atmospheric pressure with zero governor, and even if the air pressure changes (air volume changes), the gas amount follows a constant mixing ratio and the heating power can be adjusted. Since the mixing ratio can be varied by the gas volume control knob, when you change the gas fuel later, you can adjust according to the gas type.
- 4 It is connected to each type of burner from the mixed gas outlet and burning is done.
- 5 The air-gas ratio will be maintained at safety combustion range and always improve the combustion effect greatly. Turndown ratio is about 1.3 (At an air pressure of 10 kPa it is about 1.4).
- 6 It is not necessary to boost the gas and you can change the thermal power freely by just adjusting the air butterfly valve. It is safe and easy to handle with one hand control.
- 7 By controlling the combination of "control butterfly valve" and "control motor", various automatic control such as P, PI, PID, etc. is possible as well as 2 position control." control but also P, PI, PID, control.



Main Usage

- mixing device of gas and air
(variable by control of air line only)

Specifications

Model	VM-15	VM-20	VM-25	VM-40	VM-50	VM-65	VM-80	
Size (Rc)	1/2	3/4	1	1 1/2	2	2 1/2	3	
Maximum combustion capacity by the air pressure *(reference data)	6kPa kW	9.3	17.4	34.9	76.7	139.5	279.1	407.0
	10kPa kW	11.6	22.1	44.2	88.4	176.7	348.8	488.4

note) The combustion capacity of the venturi mixer changes somewhat depending on the burner used, the furnace conditions.

Overall size

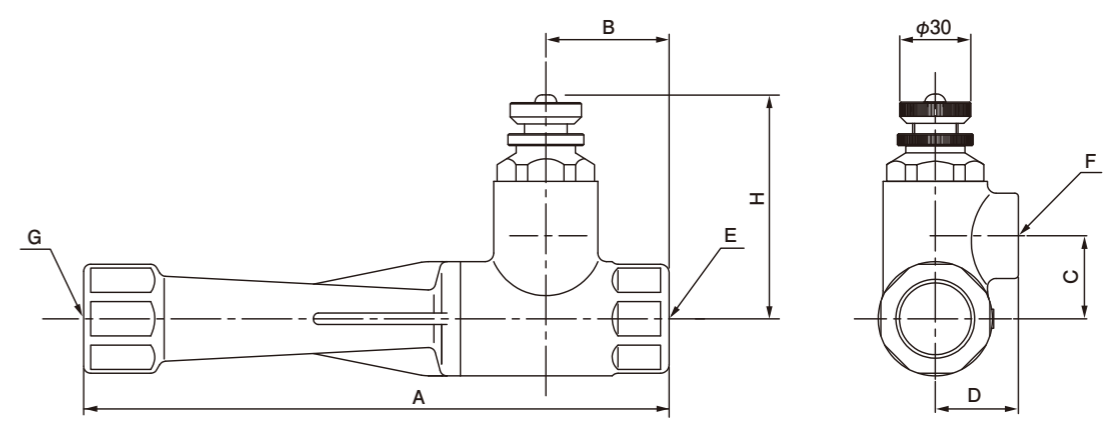

Model		VM-15	VM-20	VM-25	VM-40	VM-50	VM-65	VM-80
Overall size (mm)	A	120	195	247	334	470	490	550
	B	30	45	52	67	110	105	120
	C	23	25	35	45	65	70	80
	D	30	30	35	45	70	80	90
	H longest size	87	92	129	131	176	202	211
Connection size (Rc)	E (air)	1/2	3/4	1	1 1/2	2	2 1/2	3
	F (gas)	1/2	1/2	3/4	1	1 1/2	2	2
	G (mixing gas)	1/2	3/4	1	1 1/2	2	2 1/2	3
Air nozzle size (mm)		5φ	6.5φ	9φ	13φ	19φ	24φ	30φ

Example of flow sheet

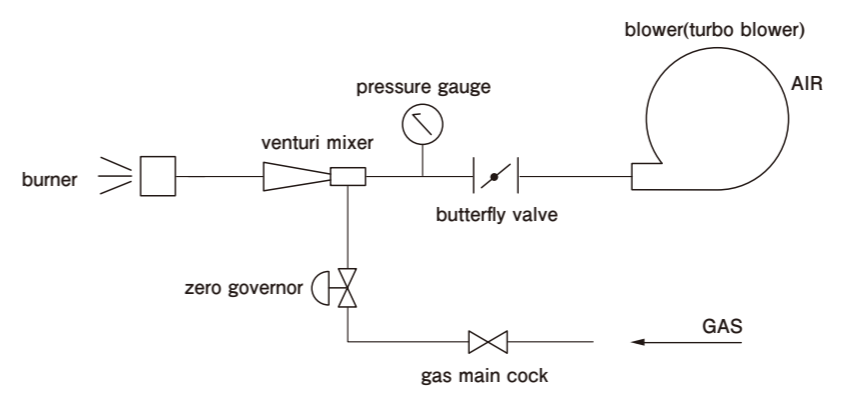

note) If you are going to take back pressure, please specify so we select exclusive zero governor.

Handling Precautions

- 1 Please be sure to use the device of appropriate ability at the gas line.
- 2 The piping on the mixed gas outlet side should be as short as possible and the closing cock etc should not be attached.
- 3 The area ratio of burner hole, and air nozzle of VM should be 4:1 or more..
- 4 As a matter of principle, combination of 1 burner with 1 VM.